

DISTINCTIVE CHARACTERISTICS

- Programmable display graphics for alphanumeric characters and animated sequences
- 64 colors of backlighting can be controlled dynamically
- Display with LCD, RGB LED backlighting
- General brightness of backlight is dynamically controlled in eight steps from dark to bright
- Operated by commands and data supplied via serial communications (SPI)
- Incorporates bitmap display function
- Dual image VRAM for quick change of displayed images
- Low energy consumption
- Dust tight construction



Viewing area: 14.4mm x 11.8mm (horizontal x vertical)

High resolution of 64 x 32 pixels

Bracket has crimped legs to ensure secure PC mounting and prevent dislodging during wave soldering

Actual Size

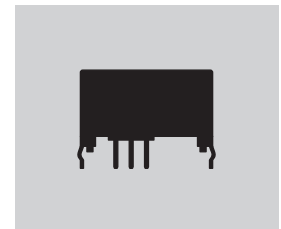

PART NUMBER & DESCRIPTION



Part Number	Terminals	LCD Mode	LED Color
IS01EBFRGB	Straight PC	Black & White FSTN Positive	Red/Green/Blue

LCD SPECIFICATIONS

Characteristics of Display

Display Operation Mode	FSTN positive; background colors, black & white
Display Condition	Transflective with built-in LED backlight
Viewing Angle Direction	6 o'clock
Viewing Area	14.4mm x 11.8mm (horizontal x vertical)
Pixel Format	64 x 32 pixels (horizontal x vertical)
Pixel Size	0.200mm x 0.285mm (horizontal x vertical)
* Operating Temperature Range	-15°C ~ +50°C (+5°F ~ +122°F)
Storage Temperature Range	-20°C ~ +60°C (-4°F ~ +140°F)
Backlight LED	RGB: red/green/blue

* In a low temperature environment (below 0°C), speed and contrast decrease when image changes. The non-indicator dot may become dense in a high temperature environment (about +50°C). Highest backlight brightness level should not be used for temperatures above +35°C.

Absolute Maximum Ratings (Temperature at 25°C)

Items	Symbols	Ratings
Supply Voltage	V_{DD}	-0.3V to +7.0V
Input Voltage	V_I	-0.3V to $V_{DD} + 0.3V$
Output Voltage	V_O	-0.3V to $V_{DD} + 0.3V$

Optical Characteristics (Temperature at 25°C)

Items	Symbols	Min	Typical	Max
Contrast Ratio	C_r	—	3.0	—
Viewing Angle ($C_r \geq 1.1$)	Up & Down	θ	90°	—
	Right & Left	ϕ	90°	—

Recommended Operating Conditions (Temperature at 25°C)

Items	Symbols	Minimum	Typical	Maximum
Supply Voltage	V_{DD}	4.9V	5.0V	5.1V
High Level Input Voltage	V_{IH}	0.8 V_{DD}	—	—
Low Level Input Voltage	V_{IL}	—	—	0.2 V_{DD}
SPI Clock Frequency	f_{SCK}	—	—	8MHz
Current Consumption	I_{DD}	** 10mA	—	*** 60mA

** 10mA: Backlighting LED is off

*** 60mA: Backlighting LEDs (Red, Green, Blue) are maximum brightness

DISPLAY BLOCK DIAGRAM & PIN CONFIGURATIONS



ISO1EBFRGB
RGB LED Backlight
Black and White LCD

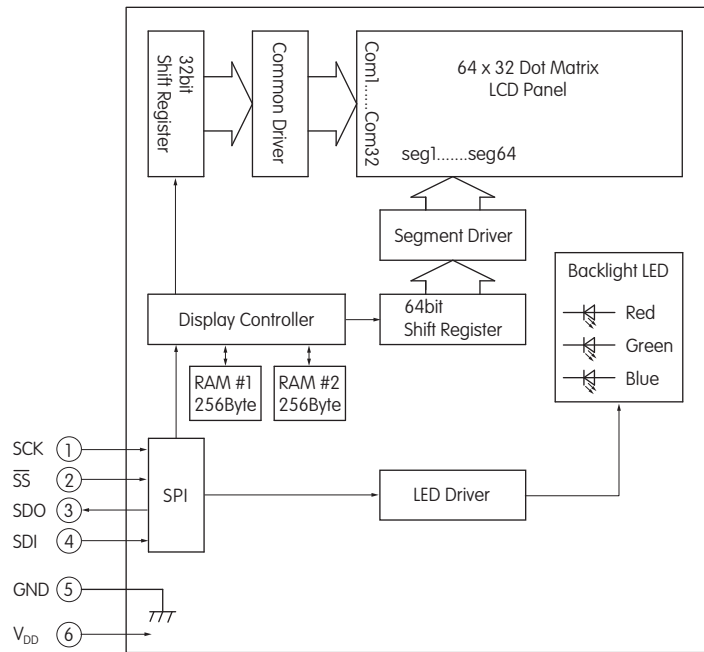

Pin No.	Symbol	Name	Function
①	SCK	Serial Clock	Clock line for SPI that synchronizes commands and data
②	\overline{SS}	Slave Select	Chip select for SPI; line is active low
③	SDO	Data Out	Data output line for SPI
④	SDI	Data In	Data input line for SPI
⑤	GND	Ground	
⑥	V _{DD}	Power	Power source for logic circuit and LCD

TYPICAL DISPLAY DIMENSIONS

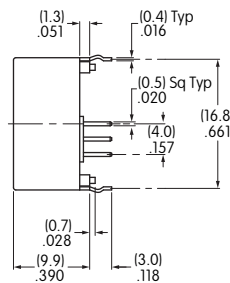
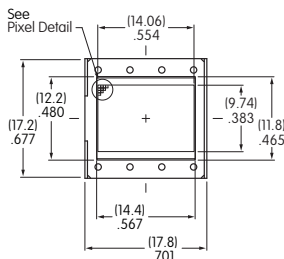

Terminal numbers are not on the device.

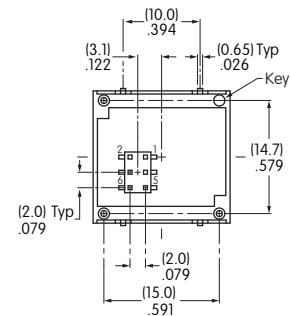

Pixel Detail

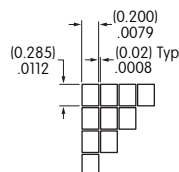

Footprint

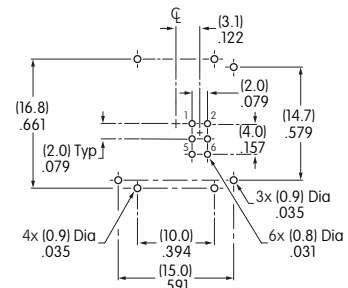

TIMING SPECIFICATIONS

SPI Characteristics (See Timing Diagram)

(Temperature at -15°C ~ +50°C and V_{DD} = 5.0V ± 2%)

Items	Symbols	Minimum	Maximum
SPI \overline{SS} Set Up Time	t_{sSS}	10ns	
SPI \overline{SS} Hold Time	t_{hSS}	10ns	
SPI_CLK Cycle	t_{cycCK}		8MHz
SPI_CLK Width	t_{hwCK}	10ns	
SPI_DI Set Up Time	t_{sDI}	10ns	
SPI_DI Hold Time	t_{hDI}	10ns	
SPI_DO Delay Time	t_{dDO}	10ns	

SPI Timing Chart (\overline{SS} Using)

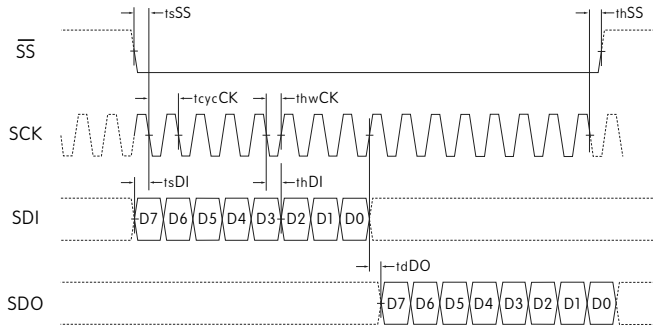

Circuit Example

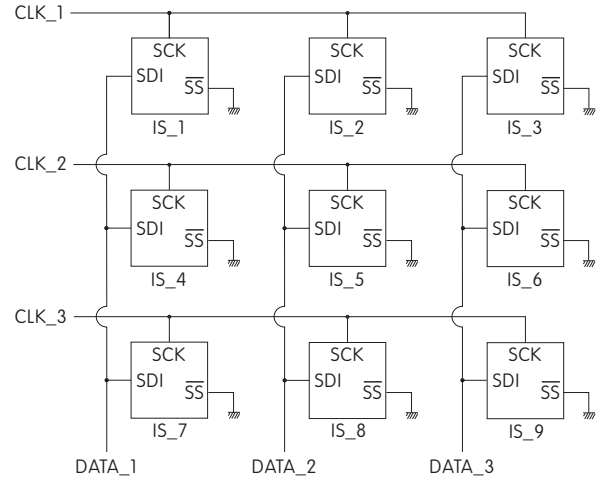

It is recommended that all \overline{SS} pins be connected to a controller pin instead of ground. A clock glitch during power up could cause the communication to fall out of sync. Toggling the \overline{SS} line resets the communication.

SPI Timing Chart (\overline{SS} Low Level Fixed)

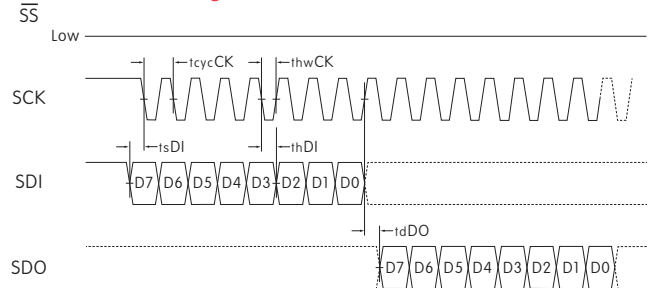

SDI and SCK shall be kept high when idle.

BITMAP

Segment	1	2	3	4	5	6	7	8	9	...	16	...	49	...	56	...	57	58	59	60	61	62	63	64								
Common	Byte8								Byte7								Byte2								Byte1							
COM1	D0	D1	D2	D3	D4	D5	D6	D7	D0	...	D7	...	D0	...	D7	D0	D1	D2	D3	D4	D5	D6	D7									
	Byte16																Byte9															
COM2	D0	D1	D2	D3	D4	D5	D6	D7																	D0	D1	D2	D3	D4	D5	D6	D7
•																	•															
•																	•															
•																	•															
	Byte256															Byte249							
COM32	D0	D1	D2	D3	D4	D5	D6	D7																	D0	D1	D2	D3	D4	D5	D6	D7

Transferring Display Data/Displaying LCD Command and Data Sequence

Command	Data (256 Bytes)																																							
0 x 55	Byte1								Byte2								...								Byte255								Byte256							
0 1 0 1 0 1 0 1	D7	D6	D5	D4	D3	D2	D1	D0	D7	D6	...	D1	D0	D7	D6	D5	D4	D3	D2	D1	D0																			

Notes: Display RAM has two screen areas. The first area is for the display on the data to be displayed next. The screens are changed when the second area is fully stored.

COMMANDS & DATA

- Transferring display data/displaying on LCD: command (1 Byte) + data (256 Bytes)
- Others: command (1 Byte) + data (1 Byte)
- Commands can be accepted only when all bits coincide; otherwise, they are not acknowledged
- Additional commands will not be received until the communication of commands (1 Byte) and data (256 or 1 Byte) is completed
- There is no time limit from the beginning to end of data receipt
- Commands may be executed consecutively (no need to wait between commands)
- Irregular commands or data are not recognized
- Initial status at power activation: LCD display off, LED off (brightness 1/20, color off)

Transferring Display Data/Displaying on LCD

Command		Data	Remarks
Hex	Binary		
0 x 55	01010101	256 Bytes (64 x 32 = 2,048 bits)	See previous page for details of bitmap data

LED (Backlight) Color Set

Command		Data	Remarks
Hex	Binary		
0 x 40	01000000	R R G G B B 1 1 2 bits x 3	For each of RGB: 00 = off 10 = 1/2 01 = 1/4 11 = full

LED (Backlight) Brightness Set

Command		Data	Remarks
Hex	Binary		
0 x 41	01000001	* * * 1 1 1 1 1 3 bits	For leading 3bits: 000 = 1/20 (dark) 100 = 1/3 001 = 1/10 101 = 1/2 010 = 1/7 110 = 2/3 011 = 1/5 111 = full (bright)

Reset (Returning to Initial Status at Power Activation)

Command		Data	Remarks
Hex	Binary		
0 x 5E	01011110	0000011	Returning to initial status at power activation

PRECAUTIONS FOR HANDLING & STORAGE OF LCD 64 x 32 DEVICES

Handling

1. The IS Series devices are electrostatic sensitive.
2. Limit operating force to keytop to 100.0N maximum, as excessive pressure may damage the LCD device.
3. The IS series devices are not process sealed.
4. If the LCD is accidentally broken, avoid contact with the liquid and wash off any liquid spills to the skin or clothing.
5. Clean cap surface with dry cloth. If further cleaning is needed, wipe with dampened cloth using neutral cleanser and dry with clean cloth. Do not use organic solvent.
6. Recommended soldering time and temperature limits:
Do not exceed 60°C at the LCD level.
Wave Soldering: see Profile B in Supplement section.
Manual Soldering: see Profile B in Supplement section.
7. Excessive images may result after the same image is emitted continuously for an extended period of time.
8. The highest backlight brightness level should not be used for temperatures above +35°C.



Storage

1. Store in original container and away from direct sunlight.
2. Keep away from static electricity.
3. Avoid extreme temperatures, high humidity, gaseous substances, and all forms of chemical contamination.