

## DISTINCTIVE CHARACTERISTICS

### Compact Size

- Perfect for rack mount router and other applications with space limitations.  
Compact body size: 19.0mm (.748") x 18.0mm (.709") compared to  
Standard body size: 23.13mm (.911") x 20.59mm (.811")
- Vibrant Illumination
- Low Energy Consumption

Programmable LCD

Variety of LED Backlighting Colors

Rubber Dome

Epoxy Sealed Straight PC Terminals

Snap-in standoff for easy, secure mounting and alignment



Programmable to display graphics, alphanumeric characters and animated sequences.

Integrated liquid crystal display provides wide viewing angle with high contrast and clarity.

Viewing area 14.5mm x 11.8mm (horizontal x vertical) at 36 x 24 pixels.

Dome gives crisp tactile feedback to positively indicate circuit transfer.

High reliability and long life of one million actuations minimum.

Epoxy sealed terminals prevent entry of solder flux and other contaminants.

Optional accessories available to simplify production process.

Actual Size

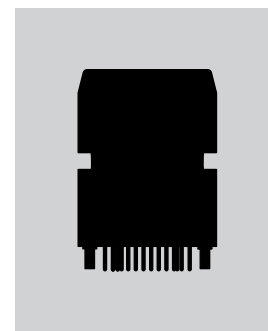

## PART NUMBER & DESCRIPTION



Part Number	Switch Description	LCD Mode	LED Color
<b>IS15BSBFP4RGB</b>	SPST Momentary ON Gold Contacts Straight PC Terminals	Black & White FSTN Positive	* Red/Green/Blue RGB

\* Simultaneous RGB illumination achieves infinite colors.

Note: Contact factory for additional options.

### SWITCH SPECIFICATIONS

Circuit	SPST normally open
Electrical Capacity (Resistive Load)	100mA @ 12V DC
Contact Resistance	200 milliohms maximum @ 20mV 10mA
Insulation Resistance	100 megohms minimum @ 100V DC
Dielectric Strength	125V AC for 1 minute minimum
Mechanical Endurance	1,000,000 operations minimum
Electrical Endurance	1,000,000 operations minimum
Operating Force	2.2 ± 0.5 Newtons
Total Travel	1.8mm (.071")

### Absolute Maximum Ratings (Temperature at 25°C)

Items	Symbols	Ratings
Supply Voltage for Logics	V <sub>DD</sub>	-0.3V to +7.0V
Supply Voltage for LCD	V <sub>LC</sub>	-0.3V to +12.0V
Input Voltage	V <sub>I</sub>	-0.3V to V <sub>DD</sub> +0.3V
Output Voltage	V <sub>O</sub>	-0.3V to V <sub>DD</sub> +0.3V

### Optical Characteristics (Temperature at 25°C)

Items	Symbols	Min	Typical	Max
Contrast Ratio	Cr	—	3.0	—
Viewing Angle (Cr ≥ 1.1)	Up & Down	θ	90°	—
	Right & Left	φ	90°	—

### DC Characteristics of LCD Drive IC (Temperature at -20°C to +60°C and V<sub>DD</sub> = 5V ±10%)

Items	Symbols	Test Conditions	Minimum	Typical	Maximum	Unit
High Level Input Voltage	V <sub>IH</sub>		0.7 V <sub>DD</sub>		V <sub>DD</sub>	V
Low Level Input Voltage	V <sub>IL</sub>		0		0.3 V <sub>DD</sub>	V
High Level Input Leakage Current	I <sub>LIH</sub>	V <sub>I</sub> = V <sub>DD</sub>			10	μA
Low Level Input Leakage Current	I <sub>LIL</sub>	V <sub>I</sub> = 0V			10	μA
High Level Output Voltage	V <sub>OH</sub>	I <sub>OH</sub> = -500μA	V <sub>DD</sub> -0.5			V
Low Level Output Voltage	V <sub>OL</sub>	I <sub>OL</sub> = 500μA			0.5	V
High Level Output Leakage Current	I <sub>LOH</sub>	V <sub>O</sub> = V <sub>DD</sub>			10	μA
Low Level Output Leakage Current	I <sub>LOL</sub>	V <sub>O</sub> = 0V			10	μA
Supply Current	I <sub>DD</sub>	f <sub>SCP</sub> = 1.0MHz			500	μA
LCD Drive Current	I <sub>LC</sub>	f <sub>LP</sub> = 2.4kHz V <sub>LC</sub> = 7.3V		500	2,000	μA

### Timing Characteristics of LCD Drive IC

(Temperature at -20°C to +60°C and V<sub>DD</sub> = 5.0V ±10%)

Items	Symbols	Minimum	Maximum
Clock Operation Frequency	f <sub>SCP</sub>		6.0MHz
Latch Pulse Frequency	f <sub>LP</sub>		50kHz
Clock High Level Pulse Width	t <sub>CWH</sub>	70ns	
Clock Low Level Pulse Width	t <sub>CWL</sub>	70ns	
Data Setup Time	t <sub>DSD</sub>	45ns	
Data Hold Time	t <sub>DHD</sub>	50ns	
Data Output Delay Time	t <sub>PDO</sub>		25ns
Latch Setup Time	t <sub>DSL</sub>	50ns	
Latch Hold Time	t <sub>DHL</sub>	50ns	
Latch High Level Width	t <sub>LWH</sub>	200ns	
FLM Setup Time	t <sub>DSF</sub>	50ns	
FLM Hold Time	t <sub>DHF</sub>	50ns	
SCP, LP Rise/Fall Time	t <sub>r</sub> /t <sub>f</sub>		15ns

### LCD SPECIFICATIONS

#### Characteristics of Display

Display Operation Mode	FSTN positive
Display Condition	Transflective with built-in LED backlight
Viewing Angle Direction	6 o'clock
Driving Method	1/24 duty. 1/5 bias (built-in driving circuit)
Viewing Area	14.5mm x 11.8mm (horizontal x vertical)
Pixel Format	36 x 24 pixels (horizontal x vertical)
Pixel Size	0.371mm x 0.445mm (horizontal x vertical)
* Operating Temperature Range	-20°C ~ +60°C (-4°F ~ +140°F)
Storage Temperature Range	-30°C ~ +70°C (-22°F ~ +158°F)
Backlight LED	RGB: red/green/blue

\* In a low temperature environment (below 0°C), speed and contrast decrease when image changes. The non-indicator dot may become dense in a high temperature environment (about +50°C).

#### Recommended Operating Conditions (Temperature at 25°C)

Items	Symbols	Minimum	Typical	Maximum
Supply Voltage for Logics	V <sub>DD</sub>	4.5V	5.0V	5.5V
Supply Voltage	V <sub>LC</sub>	7.1	7.3V	7.5
Input Voltage	V <sub>I</sub>	0V	—	V <sub>DD</sub>
Driving Frequency	f <sub>FLM</sub>	—	150Hz	—
Clock Operation Frequency	f <sub>SCP</sub>	—	—	6.0MHz

### Timing Diagram

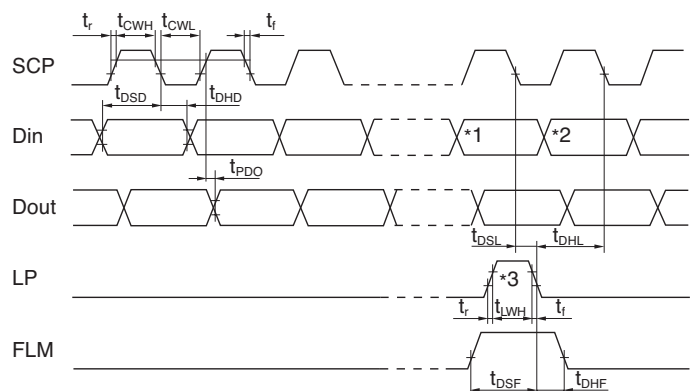

- \*1 Last data on first line
- \*2 Beginning data on second line
- \*3 Location of LP signal on first line

## BLOCK DIAGRAM & PIN CONFIGURATIONS



**IS15BSBFP4RGB**  
RGB LED Backlight  
Black and White LCD

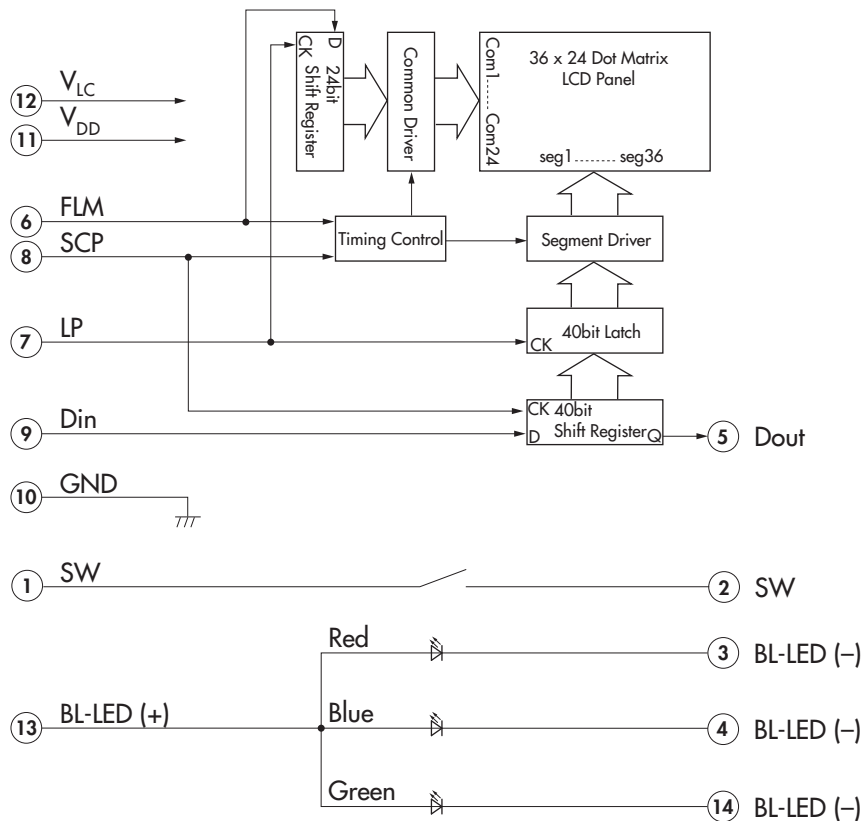

Pin No.	Symbol	Name	Function
①	SW	Terminal of Switch	Normally open
②	SW	Terminal of Switch	Normally open
③	BL-LED (-)	Terminal of Backlight LED	Cathode for red
④	BL-LED (-)	Terminal of Backlight LED	Cathode for blue
⑤	Dout	Data Output	Display serial output. Can be used to connect to Din of the next SMARTSWITCHES. As a result, many SMARTSWITCHES can be controlled with one clock and data signal.
⑥	FLM	First Line Marker	The marking signal for the first line data of LCD display. The first line of LCD will be selected by the falling edge of LP signal during the high level (FLM).
⑦	LP	Latch Pulse	Line data latch pulse will latch content of internal 40-bit shift register at falling edge for one line of display. LP will also increment the display line by one.
⑧	SCP	Serial Clock Pulse	Clock used by 40-bit internal shift register of the switch, shifting the display data bit presented at Din at falling edge.
⑨	Din	Data Input	Display serial data bit. Note: to map the display data, because of the difference between the number of internal shift register data (40) and the single line of LCD pixels (36), the first four bits of data shifted will be dummy bits.
⑩	GND	Ground	
⑪	V <sub>DD</sub>	Power	Power source for logic circuit
⑫	V <sub>LC</sub>	Power	Power source for LCD drive
⑬	BL-LED (+)	Terminal of Backlight LED	Anode for common
⑭	BL-LED (-)	Terminal of Backlight LED	Cathode for green

## RGB LED CHARACTERISTICS

Typical Electrical Characteristics (Temperature at 25°C)

Backlight Color	Symbols	Red	Green	Blue	Unit
Forward Current	$I_F$	10	8.5	8.0	mA
Forward Voltage	$V_F$	2.0	2.8	2.8	V

## ABSOLUTE MAXIMUM FOR LEDs

Electrical Characteristics (Temperature at 25°C)

Backlight Color	Symbols	Red	Green	Blue	Unit
Forward Current	$I_F$	20	20	20	mA
Forward Voltage	$V_F$	2.0 ( $I_F = 10\text{mA}$ )	2.8 ( $I_F = 8.5\text{mA}$ )	2.8 ( $I_F = 8.0\text{mA}$ )	V
Reverse Voltage	$V_R$	4.0	4.0	4.0	V
Current Reduction Rate Above 25°C	$\Delta I_F(\text{DC})$	-0.33	-0.33	-0.33	mA/°C
*Power Dissipation (LED Overall 115mW)	$P_D$	40	60	60	mW

\*For uniform light emission, Power Dissipation should not exceed the Absolute Maximum Rating, and the Forward Current should not exceed the derated Absolute Forward Current.

## TYPICAL SWITCH DIMENSIONS

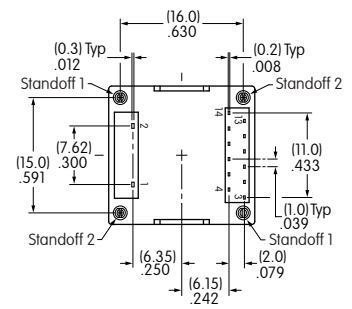
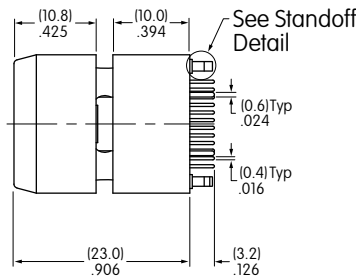
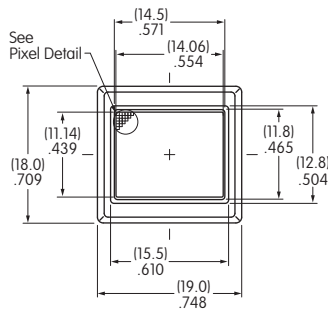

Terminal numbers are not on the switch.

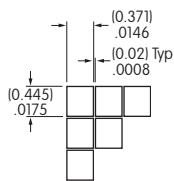

Pixel Detail

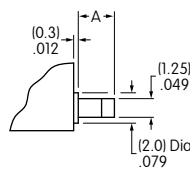

Standoff Detail

Dimension A

Standoff 1 = (2.7) .106 Standoff 2 = (2.3) .091

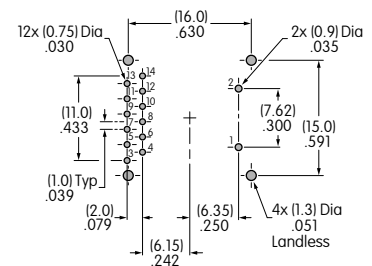

Footprint

### PRECAUTIONS FOR HANDLING & STORAGE OF LCD 36 x 24 DEVICES

#### Handling



1. The IS Series devices are electrostatic sensitive.
2. Limit operating force to keytop to 100.0N maximum, as excessive pressure may damage the LCD device.
3. The IS series devices are not process sealed.
4. If the LCD is accidentally broken, avoid contact with the liquid and wash off any liquid spills to the skin or clothing.
5. Clean cap surface with dry cloth. If further cleaning is needed, wipe with dampened cloth using neutral cleanser and dry with clean cloth. Do not use organic solvent.
6. Recommended soldering time and temperature limits:  
Do not exceed 70°C at the LCD level.  
Wave Soldering: see Profile B in the Supplement section.  
Manual Soldering: see Profile A in the Supplement section.
7. Recommendation for backlight color uniformity: Use constant current driver. For current limiting resistor method, the power source should be at least twice the backlight LED forward voltage.
8. The VLC voltage should not be applied before logic voltage. If VLC voltage is present before logic voltage, it may cause the driver logic to freeze and damage the LCD, and the driver logic may become damaged.
9. Backlight Forward Current should not exceed the derated Absolute Maximum Forward Current based on the temperature.
10. Excessive images may result after the same image is emitted continuously for an extended period of time.

#### Storage

1. Store in original container and away from direct sunlight.
2. Keep away from static electricity.
3. Avoid extreme temperatures, high humidity, gaseous substances, and all forms of chemical contamination.